

BR 710 960

Thermostatic mixing valve set for safety showers

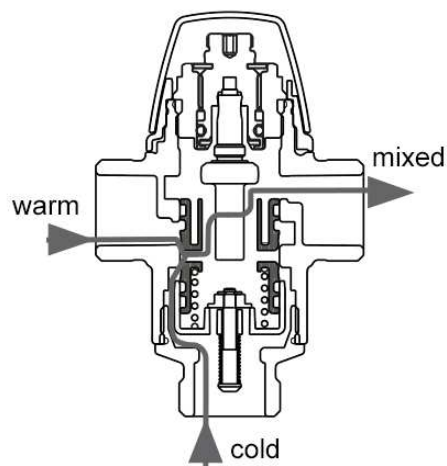
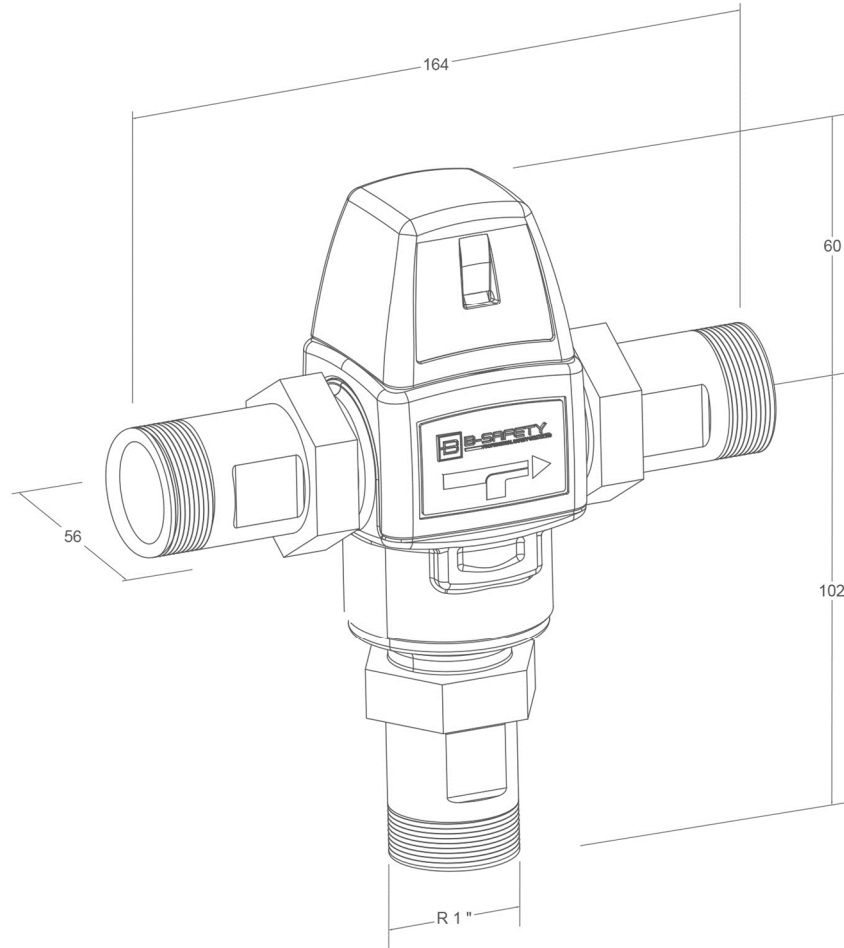

Technical description

Thermostatic mixing valve set for safety showers

The thermostatic mixing valves of the ComfortLine series are special mixing valves for eye showers and safety showers that ensure highly precise control of the water temperature and scald protection. A continuous supply of hot and cold water is required for this purpose. The thermostatic mixing valves guarantee that the correct water temperature is always available at the tapping point and that unwanted temperature fluctuations are prevented.

The scald protection reliably protects the user from scalding. The scald protection comes into play when an uncontrolled overshoot of the hot water temperature occurs or the cold water supply fails.

The thermostatic mixing valve ensures continuous water supply even if the hot water supply fails (e.g. if the hot water is turned off). The function is used when the differential pressure between cold and hot water exceeds 0.5 bar. In this case, cold water escapes at the tapping point (bypass function).

- Adjustment range 20-43°C, preadjusted to 22°C
 - Automatic check of the cold and hot water supply line
 - Hidden water temperature setting with scald protection at 43°C
 - Safety shut-off of hot water in case of cold water supply failure
 - Flow rate 160 litres / minute at 1.0 bar differential pressure, flow rate in bypass function 90 litres / minute at 1.0 bar differential pressure
 - Hot water connection 1 1/4" female, cold water connection 1 1/4" female, water outlet 1 1/4" female
 - Integrated backflow preventer in cold/hot water connection to protect the drinking water
 - Dimensions (H x W x D): 300 x 290 x 235 mm
 - according to BGI/GUV-I 850-0, DIN 1988 and EN 1717
 - according to ANSI Z358.1-2014 and EN 15154-2:2006
- Manufacturer: B-SAFETY or equal
Article-No.: BR 710 960

Technical specifications

Pressure stage:	PN 10
Operating pressure:	10 bar
Differential pressure mixing:	max. 3 bar
Differential pressure cold/hot water supply:	max. 0,3 bar
Differential pressure to trigger the bypass function:	min. 0,5 bar
Media temperature:	min. 0°C / max. 95°C
Flow rate:	160 litres / minute at 1.0 bar differential pressure
Flow rate in bypass function:	90 litres / minute at 1.0 bar differential pressure
Temperature stability:	+/- 5°C (only valid with same pressure at cold/hot water supply)
Water inlet:	1 1/4" female
Water outlet:	1 1/4" female
Dimensions (H x W x D):	300 x 290 x 235 mm

Material-overview

Material

Material description

Valve housing:	DZR Brass, dezincification-resistant, nickel-plated	CW625N
Metal parts in contact with liquids:	DZR Brass, dezincification-resistant, nickel-plated	CW625N
Cover cap:	Plastic, black	-
T-pieces, 90° angle, reducing nipples:	Stainless steel	AISI 316

www.b-safety.com

Product overview

BR 710 960

Thermostatic mixing valve set for safety showers

Performance diagram

